

SX4[®] DMX LOOP TRAY SPECIFICATIONS

Catalog # TS6111

----- CAUTION -----

When using a DMX device with a discharge lamp such as CDM or an HMI, it's suggested that you separate the power circuit for the discharge lamp from the DMX control device. When using DMX controlled units such as an Indexing TwinSpin™ or SX4[®] Gobo Changer or DMX Loop Tray, the "noise" from the discharge lamp ballast may cause some interference and/or damage the electronics. For best results we recommend providing separate line voltage to the DMX devices and the discharge light fixture.



Fire Wave Loop

See catalog numbers below for options and separate SX4[®] Case Specifications - required.

Professional Scenic Projection System

- Slides into SX4[®] Case mounted in ETC Source Four™
- Over 40 pattern loops available off-the-shelf
- Custom pattern loops available
- Can be DMX operated or used with built-in pre-programmed sequencing
- Pattern loop life span is 4,000 hours of continuous use - *ideal for theme park and retail applications*

The SX4[®]DMX Loop Tray is designed to fit into the SX4[®] Case which is attached to an ETC Source Four™ fixed focus Ellipsoidal spotlight (see SX4[®]Case Specifications). The Loop Tray will accept a continuous loop pattern. The speed and direction of the loop can be controlled from a DMX signal (by others). A DMX power supply is required.

With a large number of off-the-shelf effects using GAM FX/Loops you can quickly create a variety of different projected images. Moving clouds, rain, snow, fire, water ripples, water falls, stars and so much more are as easy as selecting the appropriate FX/Loop from your catalog. The SX4[®] has been used on Broadway, in operas, film, television, special events, theme parks and retail store displays, anywhere that a special lighting effect is required. Reliable, efficient, long life and easy to use features set the SX4[®] projection system apart from all other choices.

Item #	Description
TS6111	SX4 [®] DMX Loop Tray
TS6111FS	SX4 [®] DMX Loop Tray & Shutters
TS6211	DMX Loop Tray
TS6211FS	DMX Loop Tray & Shutters

Power supply (order separately) is required in both stand alone and DMX operation. DMX cable and power cables supplied by others. Power supply options as follows:

- TSPS-20** Dual power supply will operate from 90 to 230 Volts and can drive two units.
- TSPS-80** GamSpin DMX power supply operates eight units 120 Volts.
- TSPS-82** GamSpin DMX power supply operates eight units 220 Volts.



SX4[®] DMX Loop Tray
 US Patent # 6,926,427
 August 9, 2005

Dimensions:

- Wide: 11-5/16 in. (28.7 cm)
- Height: 11-1/4 in. (28.5 cm)
- Deep: 3-1/2 in. (8.9 cm)
- Weight : 3 lbs.,5 oz. (1.44 kgs.)
- With SX4[®] Case: 9lbs.,10 oz. (4.28 kgs.)
- Finish: Matte black paint
- Power Draw: .3 amp at 120v with our 24 VDC x-former TSPS-20

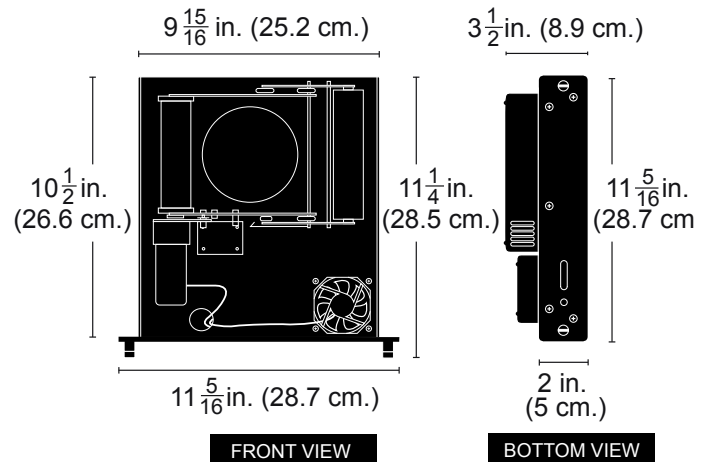

The frame for the SX4[®] DMX Film Loop Tray shall be manufactured from .063 inch (1.6 mm.) thick aluminum to minimize weight. The overall dimensions shall be 11-5/16 inches (28.7 cm.) wide at the bottom, 11-1/4 inches (28.5 cm.) high, and 3.5 inches (7.9 cm.) deep including motor control box protective housing. The spring tensioned loop roller shall be made of aluminum and the drive roller attached to the motor shall also be made of aluminum. Roller assembly plate and support systems shall be made of .065 inch (1.65 mm.) steel for rigidity. Roller will have an automatic locking device which allows it to be compressed for FX/Loop placement, and it can be easily released to operating position to maintain balanced spring tension on the loop. Low voltage 12 Volt Pittman Motor shall drive the fixed roller with silent gear box. Loop Tray shall contain internal input electronics.

Power drive mounted to tray shall operate from the 24 Volt DC supplied by separate DMX controlled power supply (specify choice). The motor drive shall be mounted in a steel case and will include the electronics and four rotary position switches for the 512 channel address and mode switch for option selection. Two 4-pin XLR connectors shall be panel mounted, a 4-pin male input and 4-pin female output for daisy chain applications. The DMX Loop Tray can be controlled using a DMX signal from conventional light boards or it can use its onboard programmed sequences with various options selected by the mode switch. SX4[®] DMX Loop Tray shall be manufactured by GAMPRODUCTS, INC., model no. TS6111.

See catalog numbers below for options and separate SX4[®] Case specifications - required.

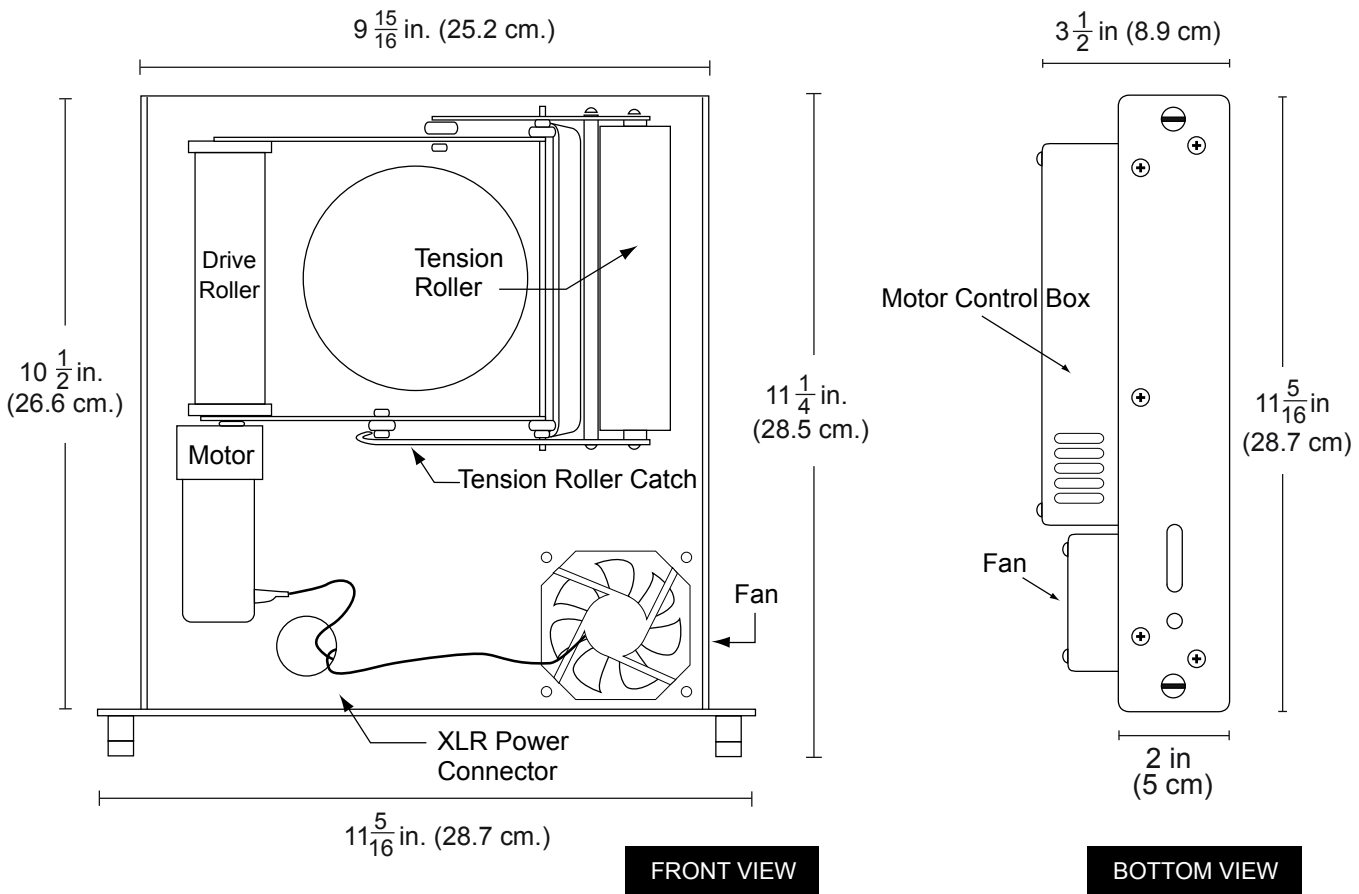

Item #	Description
TS6111	SX4 [®] DMX Loop Tray
TS6111FS	SX4 [®] DMX Loop Tray & Shutters
TS6211	DMX Loop Tray
TS6211FS	DMX Loop Tray & Shutters

Power supply (order separately) is required in both stand alone and DMX operation. DMX cable and power cables supplied by others. Power supply options as follows:

- TSPS-20** Dual power supply will operate from 90 to 230 Volts and can drive two units.
- TSPS-80** GamSpin DMX power supply operates eight units 120 Volts.
- TSPS-82** GamSpin DMX power supply operates eight units 220 Volts.